



Topaz GEM™ Trap

GEM Steam Trap Technical Datasheet

EUK | Rev 10 | Jun 2021

The GEM Trap

The GEM Trap is a low maintenance steam trap with no moving parts; it will not wear and its performance is guaranteed* on saturated steam for 10 years. The unique orifice and multistaged throat technology utilises the expansion of the flash steam created by the pressure differential across the trap to control the flow of condensate.

Operating over variable loads, the GEM Trap will suit all industrial applications. The single piece bodies are manufactured from wear and corrosion resistant grades of stainless steel.

The GEM Trap is the most energy efficient steam trap on the market and is supplied with a full sizing and commissioning service.

THE TOPAZ GEM TRAP

Topaz Traps are designed for hygienic clean steam applications. They have a crevice free body and no moving parts so they are less susceptible to bacterial growth than an equivalent mechanical trap.

- ▶ Designed for hygienic and clean steam applications
- ▶ FDA guideline compliant
- ▶ Stainless steel 316L
- ▶ Crevice free body
- ▶ All Topaz Traps are degreased before packing and dispatch

Suitable Applications

- ▶ Hygienic and clean steam applications
- ▶ Suitable for low condensate duty and process applications
- ▶ Dockweiler and Tri-Clover® fittings

Rating

	PMA	TMA
Dockweiler / Tri-Clover	10 barg (145 psig)	200°C (392°F)

Maximum temperatures and pressures are subject to the gaskets used in the fittings.

Available Spares

- ▶ No spares required

Sizes & Connection Types Available

	Dockweiler Clamp	Tri-Clover® Clamp
DN15 / ½"	✓	✓
DN20 / ¾"	✓	✓
DN25 / 1"	✓	✓



Key GEM Trap Benefits

Quality, Efficiency, Reliability and Service

Permanent Energy Savings

- ▶ Typical payback < 2 years
- ▶ Inherently more efficient than mechanical steam traps

10 Year Performance Guarantee*

- ▶ No moving parts to wear or fail
- ▶ No inserts – no leak path

Reduced Maintenance

- ▶ No on-going trap surveys
- ▶ Minimal annual maintenance

Improved Process Control

- ▶ No pressurisation of condensate return system
- ▶ Elimination of steam trap related waterhammer

Performs Across Industrial Variable Loads

- ▶ Each trap supplied with full sizing and commissioning service

* Reduced guarantee offered for superheated steam





Topaz GEM™ Trap

GEM Steam Trap Technical Datasheet

EUK | Rev 10 | Jun 2021

Product Diagram

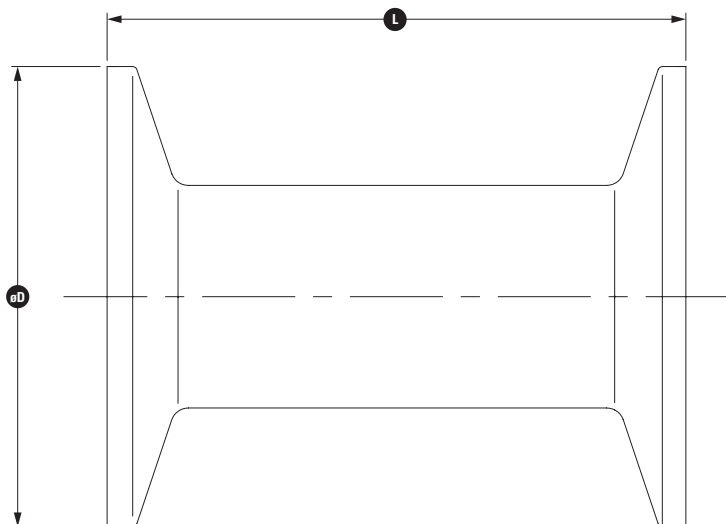

Dimensions & Weights

	Fittings	ø D	Length (L)	Weight
T15 (DN15 / ½")	½" clamp pipe	25mm	55mm	0.1kg
T20 (DN20 / ¾")	½" clamp pipe	25mm	55mm	0.1kg
T25 (DN25 / 1")	1" clamp pipe	52mm	65mm	0.3kg

Materials

Part	Material
Trap Body	Stainless Steel ASTM A479 316L / EN 10088-3 1.4404

Surface Finish

- ▶ Smooth internal surfaces to 0.5µm Ra (equivalent to 240 grit)

An inspection report can be provided with each trap if requested at time of order. Surface finish can be further improved by electropolishing. Electropolishing will incur additional cost, quotations supplied on request.

- ▶ Full product traceability is part of our Quality Assurance procedure
- ▶ Type 3.1 material certification to EN 10204:2004
- ▶ Thermal Energy reserve the right to amend material specification

All certification/inspection requirements must be stated at time of order placement.

FOR FURTHER INFORMATION

For further information on the full GEM™ Trap range contact us at technical@thermalenergy.com or visit www.thermalenergy.com

