



## TECHNICAL SPECIFICATIONS



Note: Details correct at publication. GEM Ltd reserve the right to change design and specification without notice.  
All patent design and intellectual property rights will be strictly enforced.



**United Kingdom Office**  
1 John Street, Bristol UK BS1 2HR  
e-mail: [sales@thermalenergy.com](mailto:sales@thermalenergy.com)  
tel: 0117 917 7010 fax: 0117 917 7011

### Head Office

**Thermal Energy International, Inc.**  
36 Bentley Avenue, Ottawa ON, Canada K2E 6T8  
e-mail: [sales@thermalenergy.com](mailto:sales@thermalenergy.com)  
tel: 613.723.6776 fax: 613.723.7286  
[www.thermalenergy.com](http://www.thermalenergy.com)

# GEM TRAP TECHNICAL SPECIFICATIONS

## GEM TRAP PRODUCT RANGE

The types of traps detailed within this document are designed to suit all types of applications and standard fitting arrangements. The majority of applications are served by either the 'Sapphire' GEM Trap (for screwed pipework at low pressure) or the 'Ruby' GEM Trap (for flanged connections at high pressure). For all welded pipework or systems in explosive areas, the 'universal' / 'quick fit' bolt on 'Emerald' GEM Trap is available.

## TRAP SIZING & SPECIFICATION

### TRAP SIZING

#### Mechanical Steam Traps

Makers and suppliers of mechanical steam traps provide sizing graphs for customers or designers to take on the responsibility of trap sizing. Hence if the sizing or specification is incorrect, new alternative traps have to be purchased. This arrangement is onerous to the customer / designer as there is a bewildering array of types and makes of mechanical traps, all with a range of operational pros and cons, which are guaranteed to fail due to their mechanical components.

#### GEM Steam Traps

GEM Engineers specify and size all GEM Traps as part of our standard 10 Year Performance Guarantee provided with all GEM Steam Traps (details included within the Installation and Maintenance Instructions). This ensures;

- a) the correct specification from a small range of traps, each with the same operational characteristics.
- b) optimum sizing from our extensive database developed over decades, giving operational efficiency, reliability and safety of the steam system.

#### Individually Sized Traps

In all but very repetitive installations all GEM Traps in the product range are individually sized. Each trap is given a location reference, unique serial number and a size/configuration reference. Quotation and delivery notes provide application details including heating / condensate loads, to ensure that each trap is fitted in its intended position. Full records are kept for each trap, so if you are ever unsure of the intended location of a GEM Trap simply contact GEM Ltd.

#### Generic Sized Traps

Very repetitive applications such as drip legs and trace heating in refineries and large chemical plants do not justify individually sized traps. Hence generic loading details are established for each different section of the system and the 'Quartz' or 'Ruby Filter' are supplied in batch numbers.

#### Sizing Pledge

This gives customers peace of mind as, in the event of incorrect / inaccurate sizing data being used for whatever reason, alternative capacity GEM Traps are provided free of charge.

## PRESSURE CERTIFICATION

All types and sizes of GEM Traps have been pressure tested and witnessed by Lloyds. Certification is available from [www.gemtrap.com](http://www.gemtrap.com).

## MATERIAL CERTIFICATION

Trap bodies are machined from stainless steel bar stock from European steel mills and full product traceability is part of our Quality Assurance procedure. Material certification 'type 3.1' according to BS EN 10204:2004 (E) are available on request.

# INTERNATIONAL STANDARDS FOR STEAM TRAPS

The National and International Standards that directly apply to steam traps are listed below. They are intended to ensure that the user / designer has full knowledge of a trap's characteristics and that it meets legislation requirements.

## "AUTOMATIC STEAM TRAPS – DEFINITION OF TECHNICAL TERMS" ISO 6552 : 1980

Gives precise definition of terms which should be used. They include the following with our comments in brackets;

PMA - Maximum allowable pressure, in 'bar'  
"Maximum pressure that the shell (body) of the steam trap can withstand permanently at a given temperature." (with some manufacturers the given temperature is only 120°C which makes this term irrelevant but with GEM Traps this is the PMA at the TMA temperature)

PMO -Maximum operating pressure, in 'bar'  
"Pressure for which a steam trap is rated by the manufacturer" (with GEM Traps this is the same as the PMA)

TMA -Maximum allowable temperature, in °C'  
"Maximum temperature to which the shell (body) of the steam trap can be raised permanently at a given pressure." (with some manufacturers the given pressure is only atmospheric which makes this term irrelevant but with GEM Traps this is the TMA at the PMA pressure)

TMO -Maximum operating temperature, in °C'  
"Maximum temperature for which the operation of the trap is guaranteed." (with GEM Traps this is the same as the TMA)

PN - Nominal pressure  
Permissible working pressure dependent on materials, design & working pressures / temperatures and relates more to the pipework e.g. 'PN40'

## "MARKING OF AUTOMATIC STEAM TRAPS" ISO 6553 : 1980, EN 26553 :1991

Gives the minimum basic marking requirements which include the manufacturer's name and/ trade mark and flow direction indication. These are exceeded by GEM Traps as all traps are engraved with the web address, serial / batch numbers, line size and both maximum allowable pressures and temperatures, PMA & TMA.

## "METHODS FOR DETERMINATION OF STEAM LOSS OF AUTOMATIC STEAM TRAPS"

ISO 7841 : 1988, EN 27841 :1991

This standard specifies two methods of measuring and comparing the efficiency of fully functioning steam traps. Any laboratory studies that are not conducted in accordance with this standard are likely to be misleading and inaccurate and should be treated with caution. This standard was used in the "Performance Testing of Steam Traps" by Dr. Walker of Queen's University Belfast. The testing was performed over varying loads on all commonly used mechanical traps, as well as a GEM Trap, and concluded "the venturi orifice trap proved to give the best performance in terms of steam loss under normal operating conditions". It should be noted that this study did not address or measure steam loss through failed or worn mechanical traps, which is quoted by manufacturers at 53kg/hr for just one failed 20mm NB trap at 14bar(g). Copies of the University's report and manufacturers' details of steam losses through their failed traps are available from GEM.

## OTHER STANDARDS APPLICABLE TO MECHANICAL STEAM TRAPS THAT ARE OF LESS RELEVANCE:

"Face-to-face dimensions for flanged automatic steam traps"  
ISO 6554 : 1980 EN 26554 : 1991

"Classification of automatic steam traps"  
ISO 6704 : 1982 EN 26704 : 1991

"Methods for determination of discharge capacity of automatic steam traps"  
ISO 7842 : 1988 EN 27842 : 1991

"Production and performance characteristic tests for automatic steam traps"  
ISO 6848 : 1981 EN 26948 : 1991

# TECHNICAL SPECIFICATIONS

## SAPPHIRE GEM TRAPS SETS

	15mm	20mm	25mm	40mm	50mm
Supplied with					
Strainer	✓	✓	✓	X	X
Unions	✓	✓	✓	✓ 2N <sup>o</sup> Female	✓ 2N <sup>o</sup> Female
GEM Insulation Bag	✓	✓	✓	X	X
Materials	303 Stainless Steel				
Trap Body	316L Stainless Steel				
Unions	316L Stainless Steel – Spherical seats				
Strainer Body	316L Stainless Steel				
Strainer mesh	Reinforced 40 mesh 316 Stainless Steel				
Strainer gaskets	'METACAM' 316 Stainless Steel Core and Graphite faced				
Thread	BSP to BS21, ISO7/1 & ISO228/1 NPT to order				
Operating Parameters	17.2 bar (250 psi)				
PMA	400°C (750°F)				
TMA					
Dimensions					
Length	180mm	211mm	245mm	208mm	218mm
Max Width	49mm	55mm	62mm	83mm	100mm
Max Depth	70mm	80mm	100mm	83mm	100mm

## SAPPHIRE GEM TRAP SETS FOR ALL MEDIUM PRESSURE STEAM APPLICATIONS

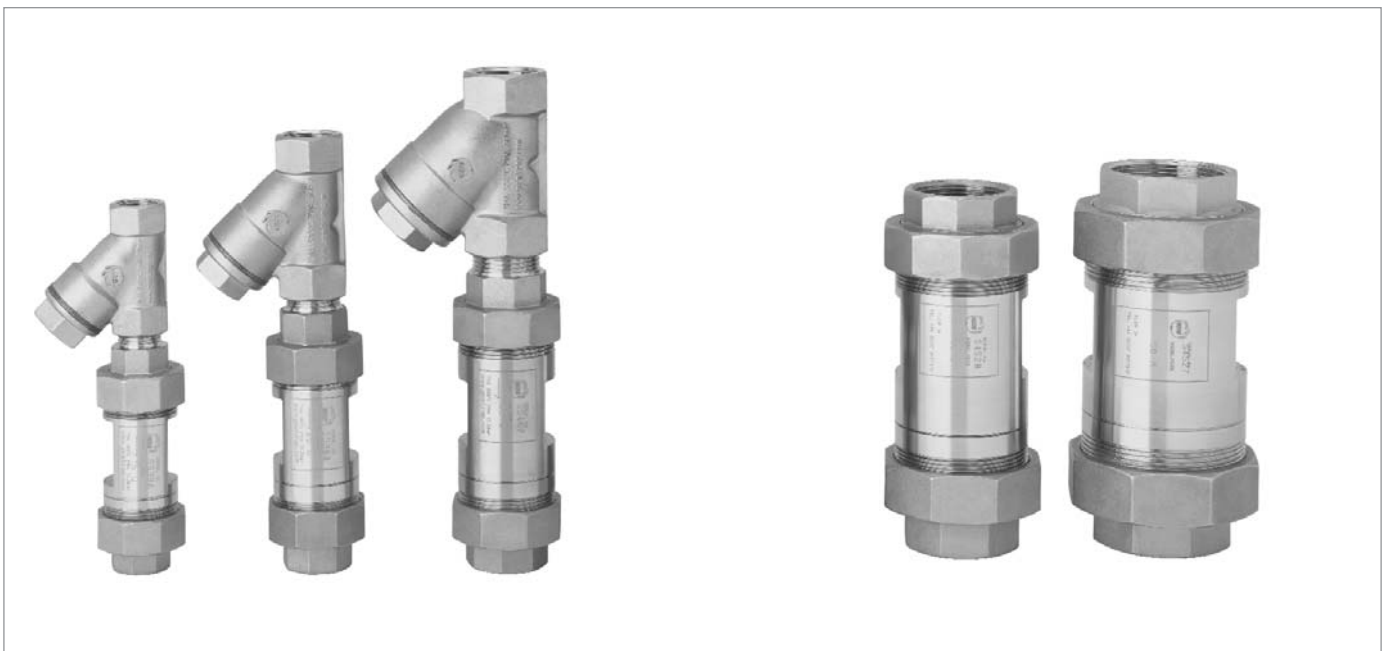

# TECHNICAL SPECIFICATIONS

## RUBY GEM TRAP SETS

	RUBY FILTER			RUBY*						
	15mm	20mm	25mm	15mm	20mm	25mm	40mm	50mm	80mm	100mm
Materials	303 S stainless Steel			303 S stainless Steel						
Body	316 Stainless Steel mesh			None						
Optional Filter	on 304 Stainless Steel ring base			None						
Filter mesh	50 mesh			None						
Operating Parameters	100 bar (1450 psi) – dependent on flange specifications			100 bar (1450 psi) – dependent on flange specifications						
PMA	500°C (940°F)			500°C (940°F)						
TMA	500°C (940°F)			500°C (940°F)						
Dimensions										
Length of head	26mm	23mm	23mm	20mm	20mm	20mm	30mm	30mm	30mm	40mm
Length of spigot	31mm	43mm	56mm	31mm	43mm	61mm	85mm	85mm	78mm	100mm
Diameter of head	40mm	50mm	60mm	40mm	50mm	60mm	75mm	90mm	127mm	158mm
Diameter of spigot	13mm	16mm	21mm	13mm	16mm	21mm	36mm	47mm	73mm	97mm

\*On low capacity applications a 40 mesh strainer must be fitted immediately upstream of Ruby traps (without integral filter)

## RUBY GEM TRAP SETS FOR ALL FLANGED APPLICATIONS



# TECHNICAL SPECIFICATIONS

	EMERALD GEM TRAP SETS	TOPAZ GEM TRAP SETS			QUARTZ GEM TRAP SETS*	
		15mm	20mm	25mm	15mm	20mm
Supplied with						
Filter	✓	Not required			✓	✓
Gaskets	✓	Available to order			✓	✓
Clamps and fittings	Not applicable	Dockweiler and Tri-clover fittings available to order			Not applicable	
Unions	Not required	Not applicable			Not applicable	
Quick fit connector	BSP or socket welded ends for 15mm / 20mm NB pipework	Not applicable			Not applicable	
Materials						
Body	303 Stainless Steel	316 Stainless Steel			303 Stainless Steel	
Cap	316 Stainless Steel					
Gaskets	'METACAM' 316 Stainless Steel core and Graphite faced				'METACAM' 316 Stainless Steel core and Graphite faced	
Connector	316 Stainless Steel					
Filter	316 Stainless Steel				304 Stainless Steel ring base	
Filter mesh	40 mesh 316L Stainless Steel				50 mesh 316 Stainless steel	
Bolts	316L Stainless Steel					
Thread	BSP/NPT or socket welded				BSP/NPT or socket welded	
Operating Parameters						
PMA	100 bar (1450 psi), cold hydraulic test to 200 bar (2900 psi)	10 bar (145 psi)			50 bar (720 psi) (When gasket fitted to torque of 50N/m)	
TMA	500°C (935°F)	200°C (392°F)			500°C (935°F)	
Dimensions						
Length	56mm	55mm	55mm	65mm	78mm	90mm
Diameter	60mm across cap flats	To suit fittings			36mm	36mm across flats
Connector length	56mm					
Connector depth	35mm					

\* Quartz GEM Traps are 'off the shelf' traps designed for minimal loads, e.g. drip legs and trace heating lines.

They are not tailor made by GEM for each application – consequently performance checking is the responsibility of the customer with assistance provided by GEM.

## EMERALD GEM TRAP SETS FOR USE WITH ANY BOLT ON 'QUICK FIT' CONNECTOR



# TECHNICAL SPECIFICATIONS

## TOPAZ GEM TRAP SETS FOR ALL CLEAN STEAM APPLICATIONS

- Crevice free
- Easy to sterilise and clean
- Smooth internal surfaces to 0.8 micron Ra, equivalent to 180 grit



## QUARTZ GEM TRAP SETS\* UNCALIBRATED FOR MINIMAL LOAD DRIP LEG AND TRACE HEATING LINES



## GEM INSULATION BAGS

- Velcro fixing – easy to fit and remove for maintenance
- Bright orange cover – easily located
- Weather and oil proof
- To class 'O' (Surface spread of flame) & low smoke generating, halogen free
- Location label provided
- Year on year savings, short payback periods
- Certified for use in 'ATEX Category 2' Explosive environments

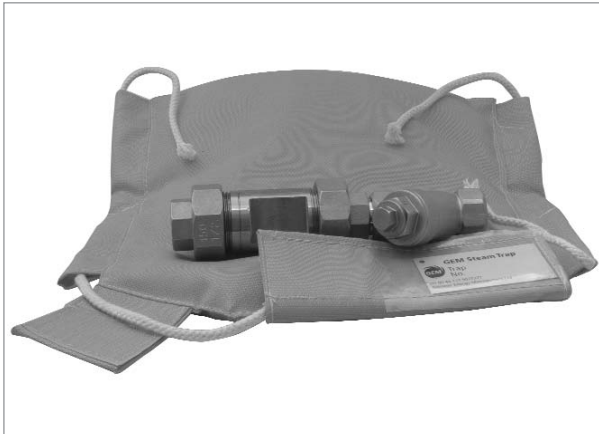

### Materials

- Cover – 'EXP903 Rubber coated glass fabric
- Filling – 50mm foil faced mineral wool
- Fixings – Velcro
- Drawstring – single strand glass fibre
- Conforms to BS5422

## GEM STRAINER

- Purpose made for steam use
- Sizes 15mm, 20mm and 25mm N.B.
- Available with BSP/NPT Threads
- High pressure and temperature ratings: TMA 500°C  
PMA 50 bar (When assembled to torque of 50N/m)
- 'METACAM' 316 Stainless Steel Core Gasket and Graphite faced
- (F8M/316L) Stainless Steel Body and Cap
- Reinforced 40 Mesh 316 Stainless Steel Filter Basket
- Standard BSP Threads to BS21, ISO 7/1 & ISO 228/1, NPT to order

