

Emerald GEM™ Trap

GEM Steam Trap Technical Datasheet



ECU | Rev 9 | Jun 2021

The GEM Trap

The GEM Trap is a low maintenance steam trap with no moving parts; it will not wear and its performance is guaranteed* on saturated steam for 10 years. The unique orifice and multistaged throat technology utilizes the expansion of the flash steam created by the pressure differential across the trap to control the flow of condensate.

Operating over variable loads, the GEM Trap will suit all industrial applications. The single piece bodies are manufactured from wear and corrosion resistant grades of stainless steel.

The GEM Trap is the most energy efficient steam trap on the market and is supplied with a full sizing and commissioning service.

THE EMERALD GEM TRAP

Emerald Traps contain GEM's inverted cone technology and a robust reinforced mesh strainer basket with large surface area to further protect the orifice from debris.

- ▶ Designed for use with the universal 2 bolt Quick Fit Adaptor
- ▶ Quick and easy to install
- ▶ Fully maintainable in-line
- ▶ Easy access to both strainer basket and orifice chamber

Suitable Applications

- ▶ Low condensate duty applications
- ▶ Line drainage / trace heating

Rating	PMA	TMA
DN15 / ½"	730 psig (50 barg)	752°F (400°C)
DN20 / ¾"	730 psig (50 barg)	752°F (400°C)

Ancillary Parts

- ▶ Insulation Jacket
- ▶ Optional drainage valve

Available Spares

- ▶ Quality Metakamm® graphite-faced gasket with SS core
- ▶ Robust SS reinforced strainer basket

Sizes & Connection Types Available

- ▶ The Emerald GEM Trap has a Universal Quick Fit Adaptor (QFA) connection. The Quick Fit Adaptor may be supplied in the following connection types:

QFA	Flanged	Threaded BSPT / NPT	Socket Weldable
DN15 / ½"	On request	✓	✓
DN20 / ¾"	On request	✓	✓



Key GEM Trap Benefits

Quality, Efficiency, Reliability and Service

Permanent Energy Savings

- ▶ Typical payback < 2 years
- ▶ Inherently more efficient than mechanical steam traps

10 Year Performance Guarantee*

- ▶ No moving parts to wear or fail
- ▶ No inserts – no leak path

Reduced Maintenance

- ▶ No on-going trap surveys
- ▶ Minimal annual maintenance

Improved Process Control

- ▶ No pressurization of condensate return system
- ▶ Elimination of steam trap related waterhammer

Performs Across Industrial Variable Loads

- ▶ Each trap supplied with full sizing and commissioning service

* Reduced guarantee offered for superheated steam

Emerald GEM™ Trap

GEM Steam Trap Technical Datasheet



ECU | Rev 9 | Jun 2021

Product Diagram

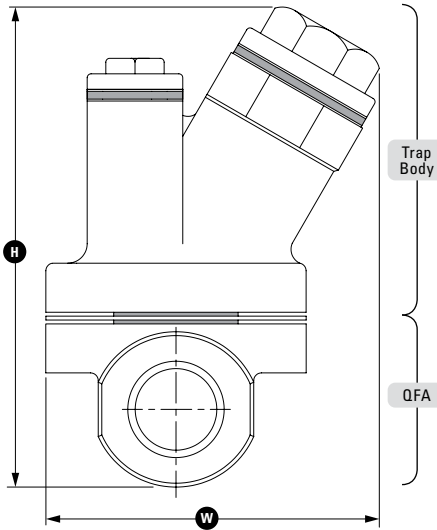

Quick Fit Adaptor (QFA)

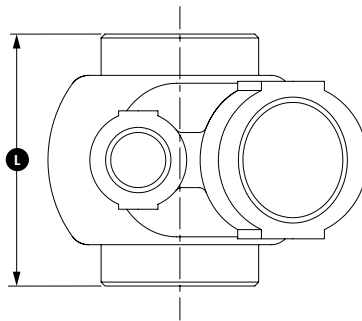

Dimensions & Weights

	EMC15 (DN15 / 1/2")	With QFA (DN15 / 1/2")
Height (H)	3 7/64"	4 39/64"
Length (L)	1 11/16"	2 7/16"
Width (W)	3 11/32"	3 11/32"
Weight	1.54 lbs	3.31 lbs

	EMC20 (DN20 / 3/4")	With QFA (DN20 / 3/4")
Height (H)	3 7/64"	4 59/64"
Length (L)	1 11/16"	2 33/64"
Width (W)	3 11/32"	3 11/32"
Weight	1.65 lbs	3.53 lbs

Materials

Part	Material
Trap Body	Cast Stainless Steel ASTM A351 CF8M / GX5CrNiMo 19-11-2 1.4408
Strainer Cap	Cast Stainless Steel ASTM A351 CF8M
Strainer Basket	Reinforced 316 Stainless Steel 60 Mesh (250 µm)
Gaskets	Metakamm® 316 Stainless Steel Core / Graphite-faced
Magnetic Filter Cap*	Stainless Steel ASTM A479 304 / EN 10088-3 1.4301 plus TEI High Temperature Magnet
Emerald Quick Fit Adaptor 1/2"	Cast Stainless Steel ASTM A351 CF8M / GX5CrNiMo 19-11-2 1.4408
Emerald Quick Fit Adaptor 3/4"	Stainless Steel ASTM A479 316 / EN 10088-3 1.4401
Bolts	Stainless Steel A2

* See GEM™ Trap Secondary Magnetic Filter Datasheet

- ▶ Full product traceability is part of our Quality Assurance procedure
- ▶ Type 3.1 material certification to EN 10204:2004
- ▶ Thermal Energy reserve the right to amend material specification

All certification/inspection requirements must be stated at time of order placement.

FOR FURTHER INFORMATION

For further information on the full GEM™ Trap range contact us at technical@thermalenergy.com or visit www.thermalenergy.com

Discharge Capacity

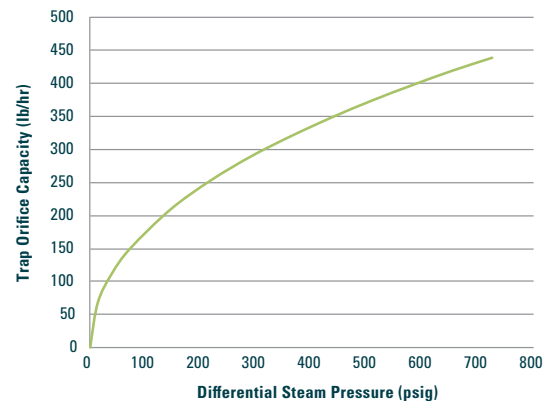

Maximum discharge capacity for Emerald Trap at saturation temperature.*

The GEM Trap will have 2-3 times the capacity at start-up.

* Actual capacity is dependent on internal sizing configuration.



An Innovative Technology Company Providing Custom Energy and Emission Reduction Solutions

technical@thermalenergy.com / www.thermalenergy.com