



Opal GEM™ Trap (DN25)

GEM Steam Trap Technical Datasheet

EUK | Rev 2 | Jun 2021

The GEM Trap

The GEM Trap is a low maintenance steam trap with no moving parts; it will not wear and its performance is guaranteed* on saturated steam for 10 years. The unique orifice and multistaged throat technology utilises the expansion of the flash steam created by the pressure differential across the trap to control the flow of condensate.

Operating over variable loads, the GEM Trap will suit all industrial applications. The single piece bodies are manufactured from wear and corrosion resistant grades of stainless steel.

The GEM Trap is the most energy efficient steam trap on the market and is supplied with a full sizing and commissioning service.

THE OPAL GEM TRAP

Opal Traps contain GEM's inverted cone technology and a robust reinforced mesh strainer basket with large surface area to further protect the orifice from debris.

- ▶ Same face to face dimension as mechanical traps
- ▶ Quick and easy to install
- ▶ Fully maintainable in-line
- ▶ Easy access to both strainer basket and orifice chamber

Suitable Applications

- ▶ Low condensate duty applications
- ▶ Line drainage / trace heating

Rating

	PMA	TMA
DN25 / 1"	PN100 / Class 600	425°C (800°F)

- ▶ PMA 100 barg (1450 psig) available on request – refer to markings on individual trap
- ▶ Designed to meet the requirements of Class 600 and PN100

Ancillary Parts

- ▶ Insulation Jacket
- ▶ Optional drainage valve

Available Spares

- ▶ Quality Metakamm® graphite-faced gasket with SS core
- ▶ Robust SS reinforced strainer basket

Sizes & Connection Types Available

	Flanged	Threaded BSPT / NPT	Socket Weldable
DN25 / 1"	On request	✓	✓



Key GEM Trap Benefits

Quality, Efficiency, Reliability and Service

Permanent Energy Savings

- ▶ Typical payback < 2 years
- ▶ Inherently more efficient than mechanical steam traps

10 Year Performance Guarantee*

- ▶ No moving parts to wear or fail
- ▶ No inserts – no leak path

Reduced Maintenance

- ▶ No on-going trap surveys
- ▶ Minimal annual maintenance

Improved Process Control

- ▶ No pressurisation of condensate return system
- ▶ Elimination of steam trap related waterhammer

Performs Across Industrial Variable Loads

- ▶ Each trap supplied with full sizing and commissioning service

* Reduced guarantee offered for superheated steam



An Innovative Technology Company Providing Custom Energy and Emission Reduction Solutions

technical@thermalenergy.com / www.thermalenergy.com



Opal GEM™ Trap (DN25)

GEM Steam Trap Technical Datasheet

EUK | Rev 2 | Jun 2021

Product Diagram

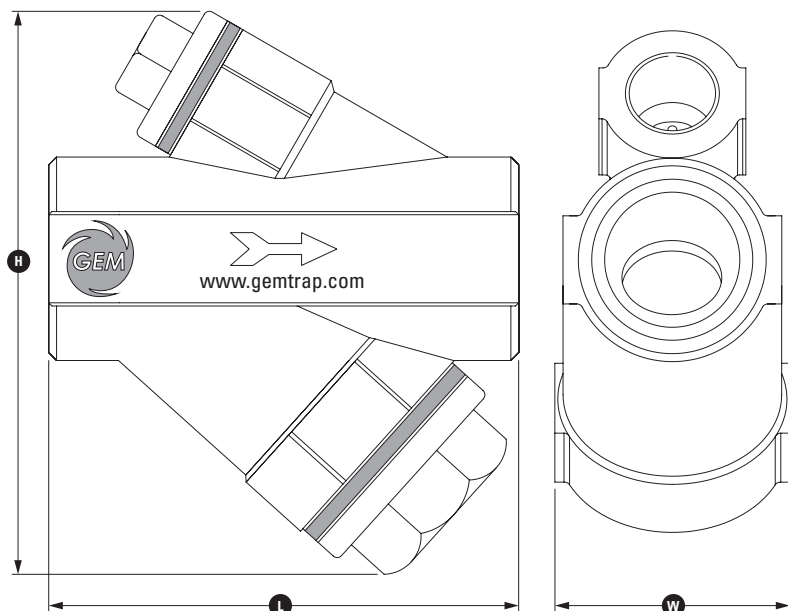

Dimensions & Weights

OP25 (DN25 / 1")

Height (H)	128mm
Length (L)	95mm
Width (W)	46mm
Weight	1.4kg

Materials

Part	Material
Trap Body	Cast Stainless Steel ASTM A351 CF8M / GX5CrNiMo 19-11-2 1.4408
Orifice Cap	Stainless Steel ASTM A479 304 / BS EN 10088-3 1.4301
Strainer Basket	Reinforced 316 Stainless Steel 60 Mesh (250 µm)
Gaskets	Metakamm® 316 Stainless Steel Core / Graphite-faced
Magnetic Filter Cap*	Stainless Steel ASTM A479 304 / BS EN 10088-3 1.4301 plus TEI High Temperature Magnet

* See GEM™ Trap Secondary Magnetic Filter Datasheet

- ▶ Full product traceability is part of our Quality Assurance procedure
- ▶ Type 3.1 material certification to BS EN 10204:2004
- ▶ Thermal Energy reserve the right to amend material specification

Discharge Capacity

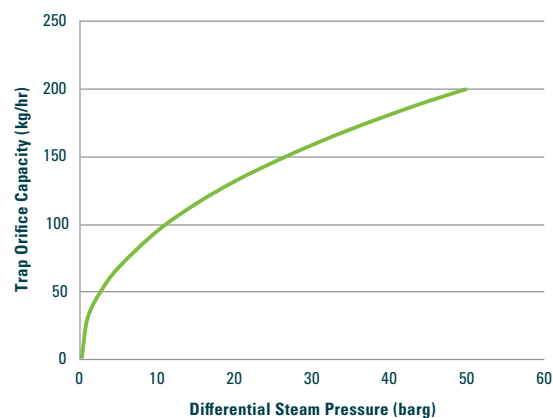

Maximum discharge capacity for Opal Trap at saturation temperature.*

The GEM Trap will have 2-3 times the capacity at start-up.

* Actual capacity is dependent on internal sizing configuration.

All certification/inspection requirements must be stated at time of order placement.

FOR FURTHER INFORMATION

For further information on the full GEM™ Trap range contact us at technical@thermalenergy.com or visit www.thermalenergy.com



An Innovative Technology Company Providing Custom Energy and Emission Reduction Solutions

technical@thermalenergy.com / www.thermalenergy.com